

BALL VALVES INTEC

K220, ½" - 4", Class 150/300

floating ball, soft seated,

single side spring loaded seat ring

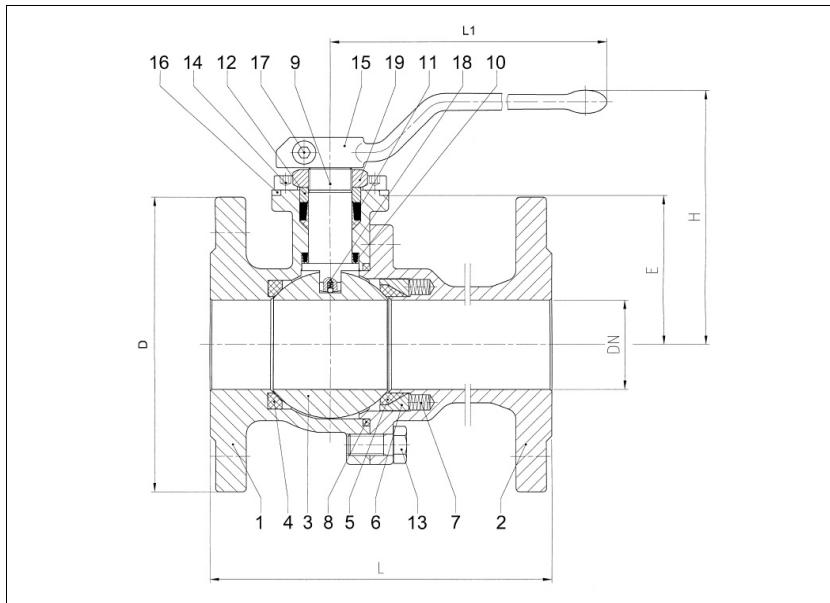

Flanged ball valve

full bore

face to face acc. to ANSI B 16.10

flanges acc. to ANSI B 16.15

Specification:

Two-piece ball valve, flanges acc. to ANSI B 16.5, face to face dimensions acc. to ANSI B 16.10, full bore, blow-out-proof stem, body material stainless steel (ASTM A351-CF8M) or carbon steel (ASTM A216-WCB), antistatic device, free of non ferrous metals, seat full chambered, single side spring loaded seat ring, stem packing Graphite/KFGN/KFAM cone ring system dynamic loaded adjustable, top flange DIN EN ISO 5211, approved by PED, stuffing box acc. to GERMAN clean air act VDI 2440, Fire-Safe acc. to API 607 and DIN EN ISO 10497, with lever.

Marking: INTEC K220

No.	Part	Material	Material
Standard design			
1	body	A216-WCB	ASTM A351-CF8M
2	cap	A216-WCB	ASTM A351-CF8M
3	ball	1.4408 (ASTM A351-CF8M)	
4	seat	KFGN/KFM	
5	spring loaded seatring	KFGN/KFM	
6	seat bearing ring	1.4571 (AISI 316 Ti)/1.4404 (AISI 316 L)	
7	spiral spring	1.4401 (AISI 316)	
8	body seal	KF	
9	stem	1.4462 (A479 UNS S31803)	
10	below seal	KFGN/Graphite	
11	upper seal	KFAM/Graphite	
12	bearing	PEEK	
13	hex. screw	A4-70 (A193-B8M)	
14	allen screw	A2-70 (A193-B8)	
15	lever	1.4408 (ASTM A351-CF8M)/1.4308 (ASTM A351-CF8)	
16	stopper	1.4301 (AISI 304)	
17	allen crew	A2-70 (A193-B8)	
18	antistatic element	1.4401 (AISI 316)/1.4571 (AISI 316 Ti)/1.4404 (AISI 316 L)	
19	hex. nut self-locking	A2/1.4301 (AISI 304)	
Fire-Safe design			
7	spiral spring	Inconel X750	
8	combined body seal	KF-Graphite	
12	Fire-Safe seal	Graphite	
	ring	1.4571 (AISI 316 Ti)/1.4404 (AISI 316 L)	
	thrust washer	PEEK	

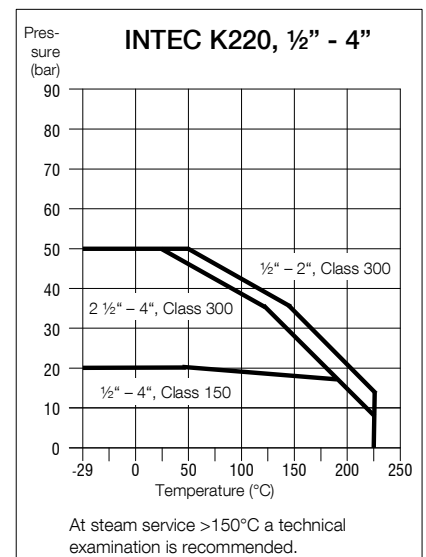

Dimensions

NPS inch	dimensions (mm)							top flange ISO	torque	
	H	L1	L 150 lbs.	L 300 lbs.	D 150 lbs.	D 300 lbs.	E		Nm** 150 lbs.	Nm** 300 lbs.
½"	95	160	108	140	89	95	39.5	F05	9	10
¾"	105	160	117	152	98	117	46	F05	11	13
1"	114	180	127	165	108	124	49.5	F05	14	18
1 ¼"	130	180	140	178	117	133	59	F05	18	25
1 ½"	135	300	165	190	127	156	76	F07	39	52
2"	143	300	178	216	152	165	83.5	F07	48	70
2 ½"	155	300	190	241	178	190	94	F07	71	118
3"	197	500	203	283	190	210	102.5	F10	121	215
4"	215	500	229	305	229	254	120.5	F10	170	333

** Necessary torque measured with treated water at Δ P acc. to pressure class and room temperature.

Ordering example:
INTEC K220, 2", Class 300,
CF8M, Fire-Safe

Subject to technical modification. 08/2019